

AP-WRC4 Installation With EV-100 Evolution Autopilot

Assumptions:

- The EV-100 autopilot installation is, or will be installed, in accordance with the Raymarine EV-100 installation manual. As a guide, refer to Figure 1 for a typical EV-100 installation.
- A Raymarine SeaTalk1 to SeaTalk^{ng} converter is, or will be, installed in accordance with the Raymarine SeaTalk1 to SeaTalk^{ng} converter installation manual.
- All required SeaTalk1 to SeaTalk^{ng} conversion parts are present. *(All required parts, except for a blue backbone cable, are included in the Raymarine E22158 converter kit, which is the recommended kit to purchase if there is no existing SeaTalk1 to SeaTalk^{ng} converter installed).*
- The AP-WRC4 is to be installed close to the SeaTalk1 to SeaTalk^{ng} converter.

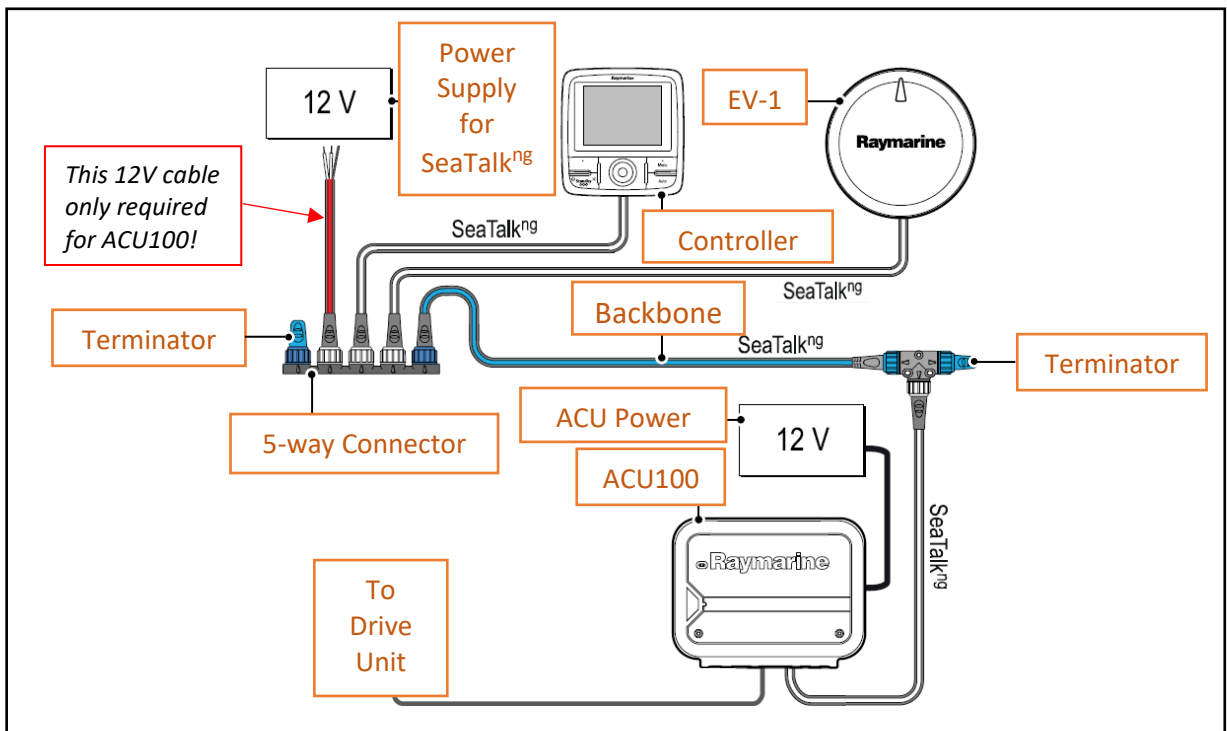

Figure 1 - Typical EV-100 Installation

Steps:

1. Turn off power to the EV-100 and 12V supply cable which supplies the SeaTalk^{ng} backbone.
2. Prepare the SeaTalk1 to SeaTalk^{ng} cable from the E22158 converter kit by cutting off the SeaTalk connector (see Figure 2) and stripping the cable back to expose the red wire, yellow wire and the screen/shield that surrounds them.

(Optional: apply clear heatshrink over the twisted screen/shield and a larger piece of black heatshrink over the cable end to make a neat job).



Figure 2 - SeaTalk Cable

Steps (continued):

3. Remove the terminator from the SeaTalk^{ng} backbone 'Tee' connector so that the backbone can be extended.
4. Install the terminator that was removed from the 'Tee' connector on one of the blue ports of the SeaTalk1 to SeaTalk^{ng} converter. Refer to Figure 3 for this and subsequent connections.
5. Connect one end of a **new** SeaTalk^{ng} backbone cable to the 'Tee' connector (where the terminator was removed) and the other end to the other blue port on the SeaTalk1 to SeaTalk^{ng} converter.
6. Terminate the wires of the SeaTalk cable in the AP-WRC4 terminals as follows:

Wire	Function	Terminal Symbol
Red	+12V	
Yellow	SeaTalk	SeaTalk
Screen/Shield	0V	Screen

7. Plug the yellow connector of the SeaTalk cable into the yellow port of the SeaTalk to SeaTalk^{ng} converter.
8. Turn on the EV-100 and the 12V supply cable which supplies the SeaTalk^{ng} backbone.
9. Check the green light on the SeaTalk1 to SeaTalk^{ng} is on (and flashing periodically).
10. Turn on the AP-WRC4 using the rocker switch at the bottom of the base unit.
11. Check that the blue 'OP' LED on the AP-WRC4 flashes 3 times after being turned on.
12. Check the orange 'ST' LED is off and remains off after 5 seconds. If the 'ST' LED turns on, wait for several more seconds and verify that it eventually turns off.
13. To finish off, mount the AP-WRC4 base unit and SeaTalk to SeaTalk^{ng} Converter in accordance with their respective manuals and tidy up the cabling. The AP-WRC4 User Manual is available from the 'Downloads' page at <https://www.madmanmarine.com>

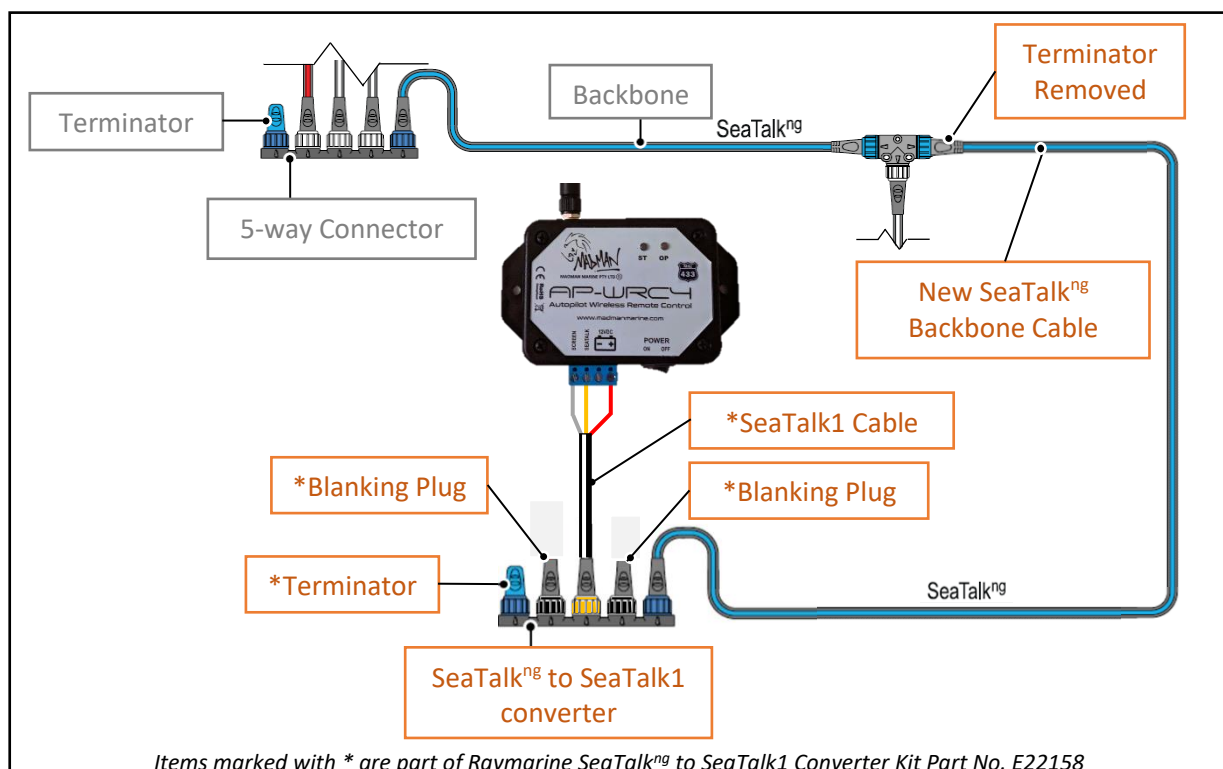

Figure 3 - AP-WRC4 Installation
www.madmanmarine.com